



Design of Online Exam Information System SMKS Al-Azis Web-Based

Azwar Try Afandi¹, Deci Irmayani², Budianto Bangun³

^{1,2}Information Management, Faculty of Science and Technology, Labuhanbatu University, 21418, Indonesia

³Information Technology, Faculty of Science and Technology, Labuhanbatu University, 21418, Indonesia

E-mail: azwartry123@gmail.com¹, deacyirmayani@gmail.com², sahatparuliansitorus4@gmail.com³

ARTICLE INFO

ABSTRACT

Article history:

Received: 10/03/2021

Revised: 20/03/2021

Accepted: 21/03/2021

Keywords:

Online Exams, Waterfall Method, UML, SMKS Al-Azis

Along with developments in information technology, the Internet would be helpful. Thanks to the internet, we will be able to conveniently provide services that can be accessed from anywhere in the world at any time. Nowadays, almost everyone has access to knowledge, one of which is the internet. Labuhanbatu Regency's Al-Azis SMKS is a private school. Every year, he finds it challenging to present the questions that his students have submitted. Similarly, at Al-Azis High School, value processing methods are still easy to implement, but it takes a long time. To solve this dilemma, we needed a computerized system to assist schools in progressing and developing. As a result, a web server-based student assessment system and an online review system were developed. Students would be able to see the results of the test immediately after taking it if the instructor processes student exam questions directly. Since this approach provides test score results directly after students have completed the exam. This data system will help teachers allocate grades to their students who have passed the test.

Copyright © 2021 Jurnal Mantik.

All rights reserved.

1. Introduction

Using the internet, we can easily create a service that can be accessed from anywhere in the world. Almost everyone nowadays has access to information, including the internet. The area of education is evolving in terms of teaching methods. One example of this advancement is the use of multimedia technologies in an online system, or, in other words, teaching over the internet network. Both formal and informal educational practices have begun to use this teaching approach since the advent of information management technology and the internet.[1]. Online teaching methods, specifically internet-based distance learning programs, are the most popular name for these modern teaching methods. The importance of comprehensive education in both academic and non-academic areas, as described by need, is emphasized in the most recent distance teaching strategies. It is hoped that online teaching methods would help in the efficient and successful teaching, transmission, and absorption of education.[2].

This management information system is part of the internal control system, including human resource management, data management, technology management, and problem-solving procedures. A management information system presents this information in an integrated human-machine (integrated) format to support organization operations, management functions, and decision-making. Model and decision making and "databases," are all examples of how to use computer hardware and software and standard operating procedures. Ordinary information systems are not the same as management information systems. They are used to view data from the organization's other systems. This term is generally used in academia to refer to the population group of information management methods related to automation or decision support.[3].

The test system combines a human work system with a computer to enable quicker and more reliable tests and assessments, allowing for a clear assessment of exam results. This examination method makes use of databases, as well as computer hardware and software.[4].

2. Method

This study employs descriptive methodology methods, which are methods for evaluating an object and presenting data in a meaningful way to comprehend an object or a collection of current events' characteristics. The waterfall approach is used in this analysis to create a model for creating information systems. The waterfall model is a well-known modelling technique. This waterfall model is linear from



concept to maintenance.[5]. The next stage will not begin until the previous one has been completed (UML). Use Case Diagrams, Class Diagrams, Activity Diagrams, Sequence Diagrams, and Component Diagrams are some of the tools that can be used.[6]

3. Results and Discussion

Figure 1. Use Case Diagram designed the system A case diagram represents the relationship or interaction of one or more actors with the system. They may also provide a high-level description of the system's functions. Use case diagrams may depict the relationship between actors and the system.

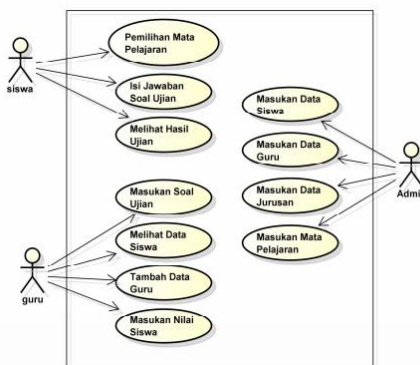

Fig 1. Use Case Diagram designed the system.

Diagram of an Activity When an individual performs a sequence of acts or meets such requirements, it is assumed to be in this state. In the diagram below, you can see the activity diagram.

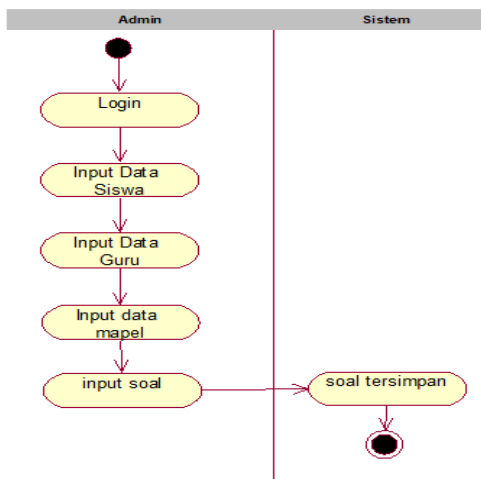

Fig 2. Admin Activity Diagram

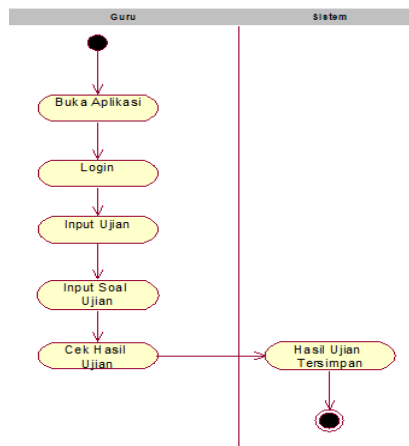

Fig 3. Teacher Activity Diagram

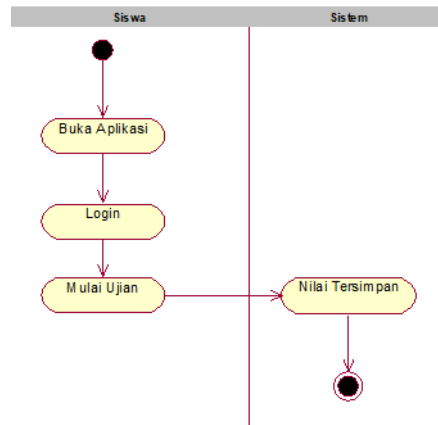

Fig 4. Student Activity Diagram

Figure 5. Admin Sequence sequence diagrams show how many objects interact. At a certain point in the system's execution, the aim is to display a collection of messages and interactions between objects.

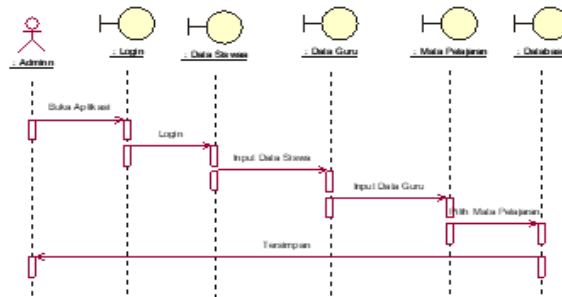

Fig 5. Admin Sequence

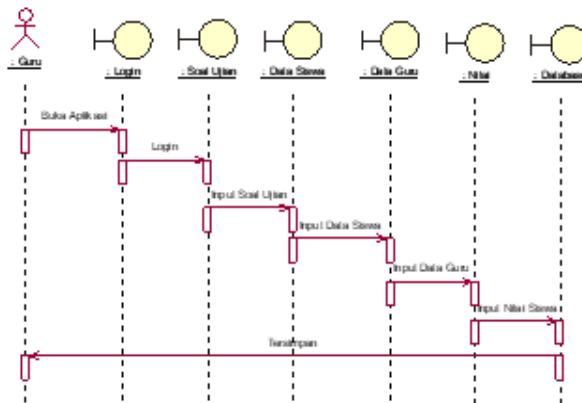

Fig 6. Teacher Sequence

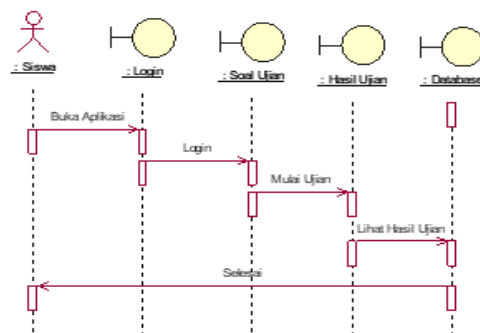

Fig 7. Student Sequence

The process of installing and checking a ready-to-use and run system is known as system implementation.

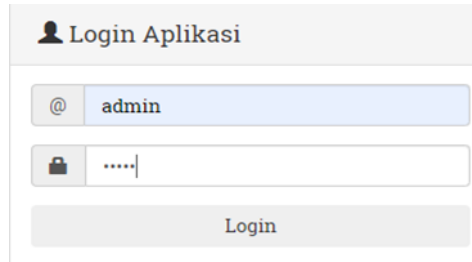

Fig 8. Login Interface

Figure 8. A login interface with a user name and password must be entered by the administrator or operator. The username and password are stored in the database. If you enter an incorrect username and password, you will not be able to proceed to the main page.



Fig 9. Main page interface

Figure 9. Main page interface As the main page display, there are menus: Dashboard, Student Data, Teacher Data, Lessons, Questions, Exam Results.

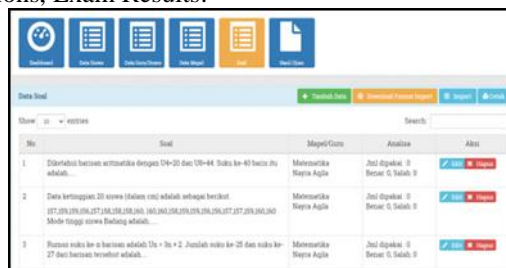

Fig 10. Interface exam questions page

Figure 10. Exam questions page in the interface. a page that shows the data for the topic that the student wants to test.

4. Conclusion

The online information system must be introduced on the Smks Al-Azis web-based system in order to take school exams, which are currently conducted manually, more effectively using a web-based data processing system. Teachers will be better able to assess student exam success using this method. The development of a web-based online assessment system that classes can use to evaluate student learning should be accurate and quick. The system can handle data by entering, storing, and printing data for report generation, as well as saving or combining all relevant data into a single database.

5. References

- [1] E. Fantini and R. S. Tamba, "Mediamorfosis Edukasi Informal Online Melalui Platform Digital Sebagai Peluang Bisnis Baru," *Maj. Ilm. Bijak*, vol. 17, no. 1, pp. 114–127, Apr. 2020, doi: 10.31334/bijak.v17i1.831.
- [2] C. A. Napitupulu *et al.*, "IMPLEMENTASI PEMBELAJARAN KOLABORATIF DARING (ONLINE COLLABORATIVE LEARNING) DALAM RANGKA PEMBENTUKAN DUKUNGAN SOSIAL MAHASISWA PG PAUD FKIP UNIVERSITAS PALANGKA RAYA," *J. Pendidik. Dan Psikol. Pint. Harati*, vol. 16, no. 2, pp. 1–17, 2020, doi: 10.36873/JPH.V16I2.2239.
- [3] E. S. Negara *et al.*, *Sistem Informasi Manajemen Bisnis*. yayasan kita menulis, 2021.
- [4] D. F. Saefudin, Y. Komalasari, and E. Maesyari, "RANCANG BANGUN APLIKASI UJIAN ONLINE STUDI KASUS: SMK 1 PGRI CIKAMPEK," *J. Teknol. DAN OPEN SOURCE*, vol. 3, no. 1, pp. 14–29, 2020, doi: 10.36378/jtos.v3i1.529.
- [5] I. R. Munthe, "Perancangan Sistem Informasi Pengarsipan Data Penduduk Pada Kantor Camat Bilah Hulu

Kabupaten Labuhan Batu Dengan Metode System Development,” *Informatika*, 2017, [Online]. Available: <http://jurnal.ulb.ac.id/index.php/informatika/article/view/666/652>.

- [6] B. H. Rambe, R. Pane, D. Irmayani, M. Nasution, and I. R. Munthe, “UML Modeling and Black Box Testing Methods in the School Payment Information System,” *J. Mantik*, vol. 4, no. 3, pp. 1634–1640, 2020, doi: 10.35335/MANTIK.VOL4.2020.969.PP1634-1640.

